

Modell 007-69
Klappsitz für Wandeinbau
 mit verdecktem Wandrahmen

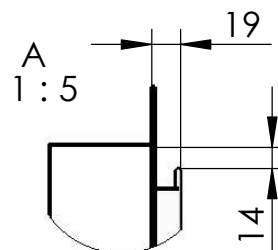

Sitzeinheit steht 19 mm über.

Modell 007-69
Klappsitz für Wandeinbau
 mit verdecktem Wandrahmen

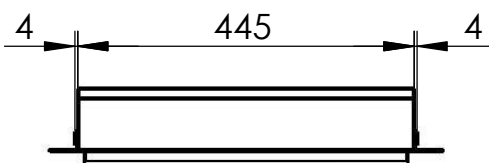
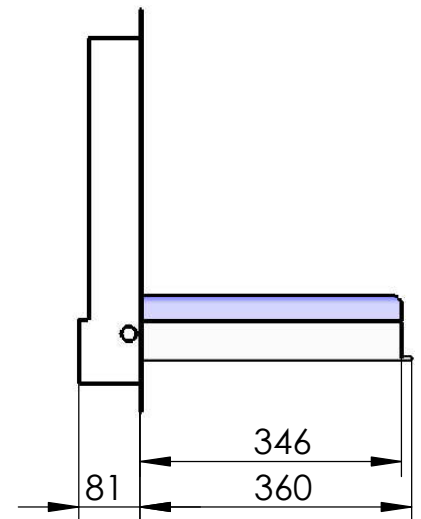
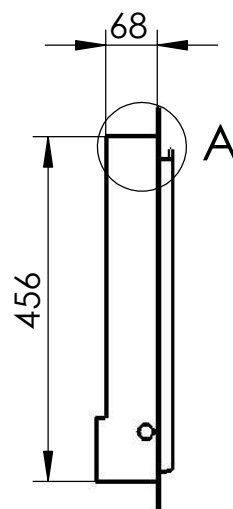
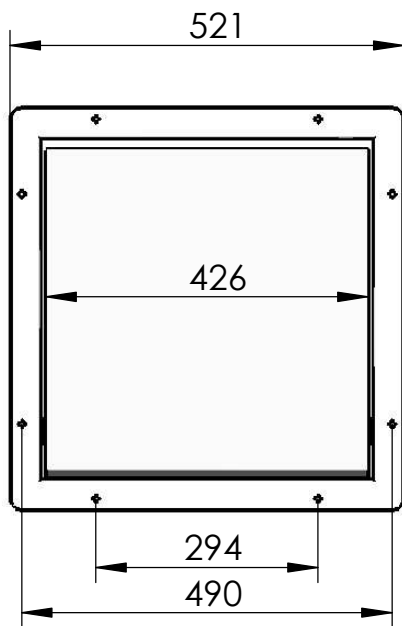
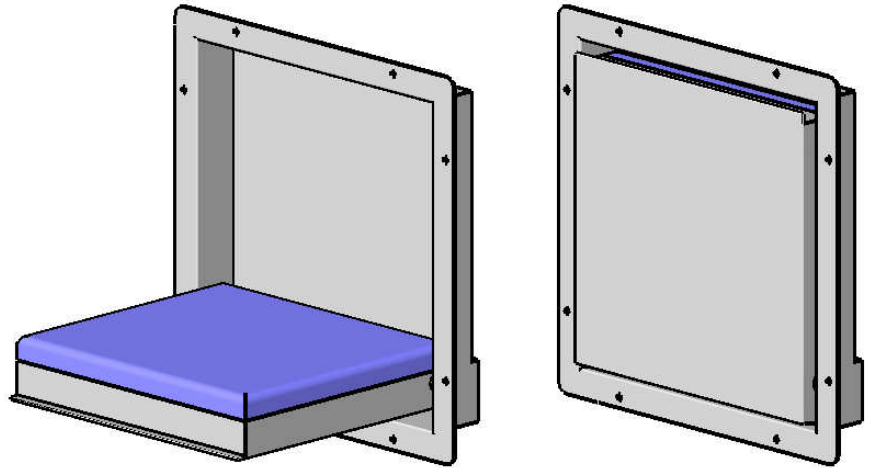
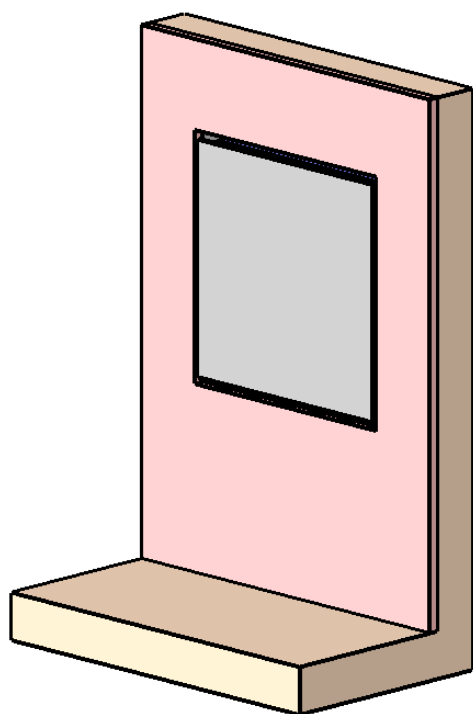

Freischnitte für Verschraubung in Verkleidung vorsehen.

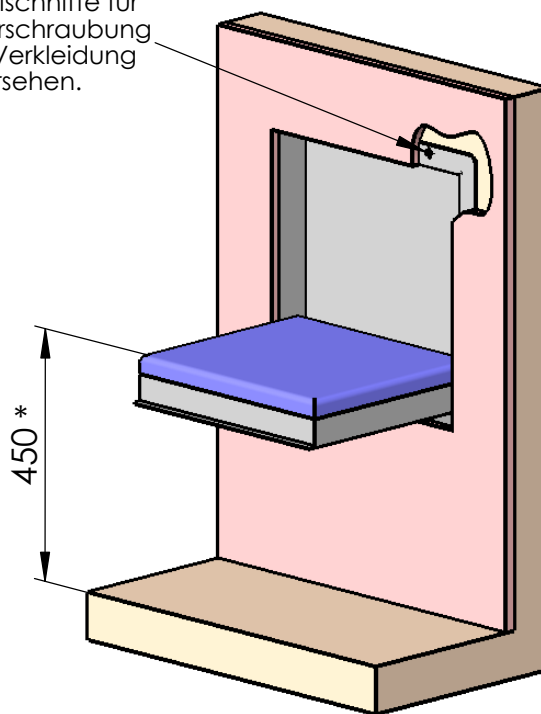

Wandausschnitt

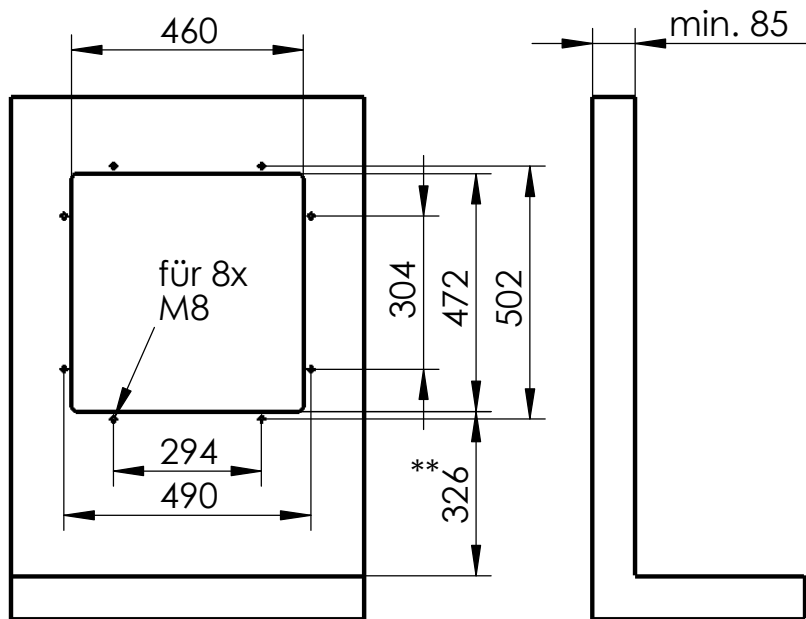

Verkleidung von hinten gesehen

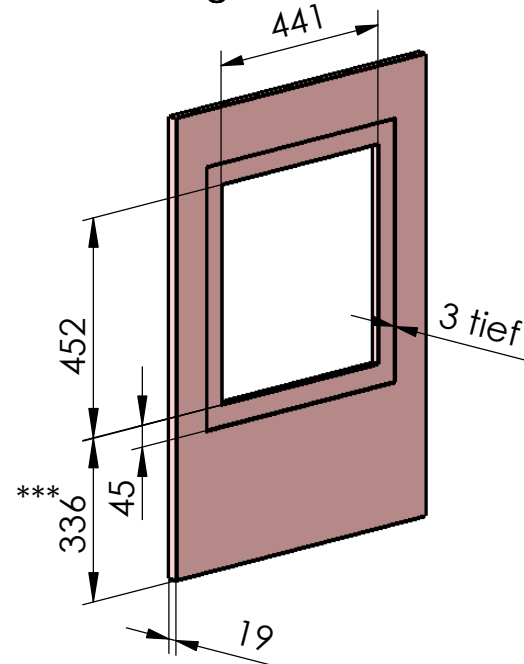

- * Sitzhöhe gemäß DIN EN 81-70: 480 bis 520 mm
- ** dementsprechend 356 bis 396 mm, statt 326 mm
- *** dementsprechend 366 bis 406 mm, statt 336 mm